

OWNERS MANUAL FOR



580 N. Westgate Dr.
Grand Junction, CO 81505 USA
1.800.999.8277
www.whitebrotherscycling.com



TABLE OF CONTENTS

SAFETY.....	PAGE 2
INTRODUCTION.....	PAGE 2
FORK INSTALLATION.....	PAGE 3
TUNING.....	PAGE 4
MAINTENANCE.....	PAGE 5,6
EXPLODED VIEWS.....	PAGE 7
WARRANTY.....	PAGE 8

IMPORTANT **CONSUMER SAFETY INFORMATION**

WARNING: RIDING A BIKE IS DANGEROUS. NOT PROPERLY MAINTAINING OR INSPECTING YOUR BIKE AND IT'S COMPONENTS IS EVEN MORE DANGEROUS. IT IS ALSO DANGEROUS TO NOT READ AND FOLLOW THESE INSTRUCTIONS.

1. NEVER REMOVE STEERER TUBE FROM CROWN. THIS IS A PRESSED IN PART. REMOVING IT WILL RENDER BOTH THE CROWN AND STEERER TUBE INOPERABLE. * MAKE SURE THE FORK CAPS AND ALL FORK HARDWARE (pinch bolts, etc.) ARE TIGHT BEFORE EACH RIDE.
2. DO NOT PERFORM ANY MODIFICATIONS OR ADJUSTMENTS THAT ARE NOT OUTLINED IN THIS MANUAL. SEE THE TUNING SECTION FOR MORE DETAILS.
3. INSPECT YOUR FORK BEFORE EVERY RIDE. INSPECT THE CROWN, TUBES, AND AXLE SEAT AREAS FOR ANY SIGNS OF FATIGUE, BENDING, CRACKING OR OTHER DAMAGE. IF YOU NOTICE ANY TYPE OF DAMAGE, DO NOT RIDE IT. RETURN IT TO YOUR DEALER OR TO WHITE BROTHERS FOR A COMPLETE INSPECTION AND NECESSARY REPAIR.
4. PERFORM ALL RECOMMENDED MAINTENANCE ACCORDING TO THE MAINTENANCE SECTION OF THIS MANUAL. FAILURE TO PERFORM MAINTENANCE COULD DRASTICALLY REDUCE THE FORK'S LIFE, PERFORMANCE AND CAUSE YOUR FORK TO BE A SAFETY HAZARD.
5. WHITE BROTHERS RECOMMENDS THAT YOU WEAR PROPER SAFETY EQUIPMENT EVERY TIME YOU RIDE, INCLUDING AN APPROVED BICYCLE HELMET. NEVER RIDE AT NIGHT WITHOUT LIGHTS.
6. ALWAYS USE GENUINE WHITE BROTHERS PARTS. USE OF AFTERMARKET REPLACEMENT PARTS AND UPGRADES VOIDS THE WARRANTY AND COULD CAUSE STRUCTURAL FAILURE.
7. WHITE BROTHERS FORKS ARE DESIGNED FOR OFF ROAD USE ONLY. THEY ARE NOT EQUIPPED WITH REFLECTORS FOR ROAD USE. IF YOU ARE GOING TO USE YOUR FORK ON THE ROAD, HAVE A DEALER OR MECHANIC INSTALL REFLECTORS THAT MEET THE CONSUMER PRODUCT SAFETY COMMISSION'S REQUIREMENTS.

**IF SERVICE BECOMES NECESSARY OR REMOVAL OCCURS, PLEASE CALL WHITE BROTHERS CUSTOMER SERVICE FOR PRODUCT EVALUATION AND DIAGNOSIS.*

INTRODUCTION

Thank you for purchasing your new White Brothers fork. Our forks are designed to help you perform at your absolute peak. Your new White Brothers fork has oil damping and is coil sprung for light weight performance. The coil spring and damper is set stock to satisfy a wide range of rider weights and riding styles. Fine tuning can be easily accomplished by changing pre-load and external damper settings. See the tuning section for details. For very heavy or very light riders, replacement springs are available. Steering accuracy is improved over conventional MTB forks by utilizing superior materials and design. Every effort has been made to make White Brothers forks very light and perform at a level superior to other forks on the market. To ensure peak performance, proper installation and periodic maintenance is required. When riding on public land, please respect the rights of others and stay on established paths and trails. By riding responsibly, you are helping ensure the future of our sport.

FORK INSTALLATION

White Brothers forks feature a 1-1/8" threadless steerer tube. If you have a threaded type fork on your bicycle, consult your dealer for the appropriate upgrade parts necessary to convert to a 1-1/8" threadless steerer tube. Check with your frame manufacturer to ensure your bike is designed for a triple clamp fork. If not, you may void your warranty.

1. Remove your old fork from the bicycle. Measure the diameter and length of your old forks steerer tube to ensure that the White Brothers steerer tube is the correct diameter and sufficient length for the installation.
2. Remove the crown race from your old fork.
3. Press the crown race onto your new White Brothers fork.(see **Figure #1**)
4. Preassemble the headset by sliding the fork steerer tube through the bearings. Then install the head sets upper race, upper triple clamp, headset spacer (optional), and stem onto the fork steerer tube. Adjust with optional spacers to your preferred height. (**See Figure #2**) **WARNING:** Refer to the head set owners manual if there are any questions about the head set installation.
5. Mark the steerer tube at the top of the stem. The steerer tube will now need to be cut to the correct length. Disassemble and cut 3mm (1/8") below the mark. Consult your dealer or mechanic if you don't have the proper tools to cut the steerer tube.
6. The star fangled nut must now be installed into the steerer tube. If you don't have the set tool we recommend dealer installation of this part. (**See Figure #3**)
7. Clean and grease all headset bearings and races to prepare them for assembly. **Note:** Replace the bearings if there is any sign of wear or corrosion.
8. Now loosely assemble the headset, stem and handle bars as done in step four. (**See Figure #2**)
9. Install the headset top cap into the star fangled nut. Tighten until there is no play in the steering. The fork should rotate freely in the head tube. Straighten the stem in relation to the front tire and tighten the pinch bolts on the stem. Tighten the pinch bolts on the upper clamp and double check that the lower clamp bolts are tight. These can easily be over tightened. We recommend tightening to 8 foot pounds. If there are any questions consult your dealer or mechanic.

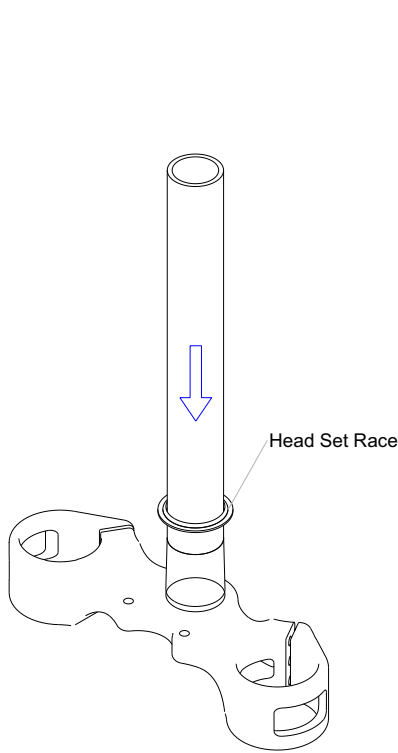

Figure #1

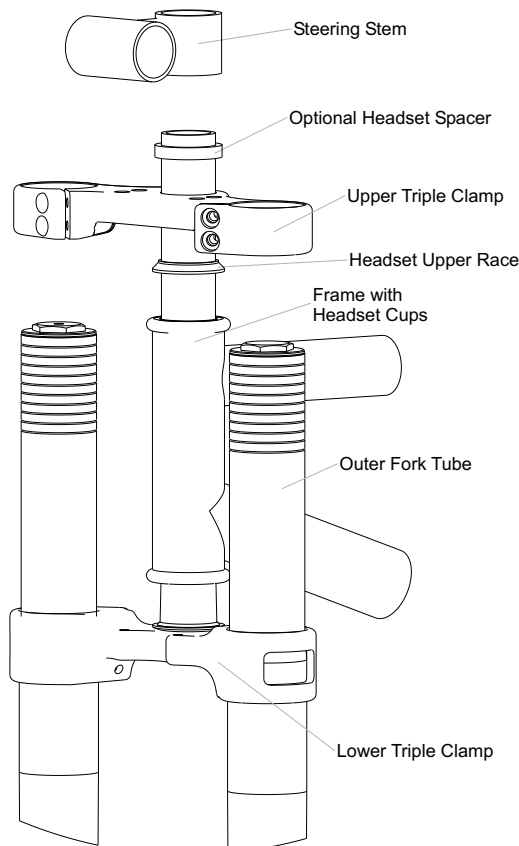

Figure #2

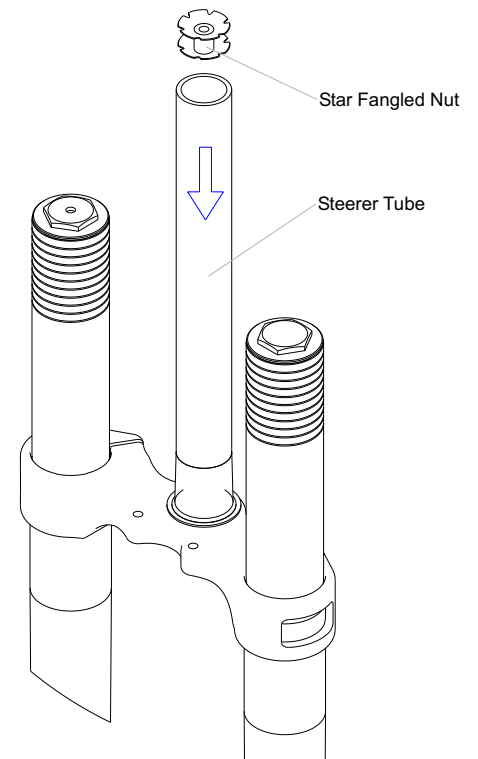

Figure #3

10. Slide the wheel in and line up the brake rotor with the brake caliper then line up the hub with the axle feet. Slide the 20mm axle through the right side foot, hub and into the left side foot. Tighten the pinch clamps after the axle is properly seated and tight.
11. Adjust your front brake according to the manufacture's instructions.
12. Check to see that the brakes are adjusted and properly working. Make sure the brake line doesn't interfere with any part of the bike when the fork is compressed and released.

Warning: When installing the wheel or a new tire, check for minimum clearance. Measure from the highest point on the tire to the under side of the crown. There must be 1/8" or 3mm more clearance than the fork's travel to ensure adequate clearance in all riding conditions. Any less clearance can cause the tire to hit the crown resulting in serious injury or death. The DH 1.8 will not work on frames with head tubes longer than 5-1/2".

TUNING

To get the most from your White Brothers fork, it is important that you tune the forks to fit your style of riding and the conditions you ride in.

INITIAL BREAK-IN PERIOD

Your new fork is designed to break-in over a period of 10 hours or more of riding. As all the parts bed into each other, the stiction (friction) of the fork will diminish and the fork will absorb the bumps better. After this initial break-in, fine tuning the spring pre-load and hydraulic damper may be beneficial to achieve the best possible fork performance for your weight and riding style.

TUNING YOUR SPRINGS

1. There are two ways to adjust your forks spring action. The first is by changing the spring pre-load and the second is changing the springs for a completely different rate. Your White Brothers fork comes equipped with a medium rate spring adjusted with a minimum of pre-load. Minimum pre-load means that at full extension, the fork caps just touch the top of the springs. This setting usually gives the best ride characteristics. Excessive pre-load will cause the fork to top out and may indicate that you need a stiffer spring.
2. **Pre-load** can be changed by adding or removing pre-load spacers from under the main spring. More pre-load will have less sag and a firmer feel. Less pre-load will have more sag and a softer feel.
3. Though the medium rate springs that are fitted in your White Brothers forks should satisfy most rider weights and conditions, for very light or very heavy riders, a spring change may be necessary. If you are a lightweight rider and feel you are not getting the full travel out of your fork, ordering the optional light fork springs for your fork would be recommended. For heavier weight riders that feel they are constantly using too much fork travel, the optional heavy fork springs would be recommended. A good way to test the travel you are using with your fork is to tie a zip tie around fork stanchion and slide it up to the bottom of the forks wiper seal. Go and ride a variety of conditions you normally experience, including some conditions that you feel should use the full fork travel. After the ride, inspect the position of the zip tie. Measure that position from the fork wiper seal to the axle clamp. Next remove the fork cap and compress the fork to full bottom out. If the zip tie moves more than 1/4", your spring is probably too stiff and a change to a softer spring may improve your ride. Very heavy riders may note that the zip tie slides down the fork stanchion quite far even over minor bumps and this could indicate the need for a heavy spring rate.
4. If after adjusting as outlined in steps 1-3 you feel the fork is too soft or too firm, you may need to change the spring out. Contact White Brothers for a replacement spring. See the "Disassembly of the Spring Leg" and "Reinstalling the Springs and Left Hand Top Cap" sections to replace the spring.

TUNING YOUR DAMPER

1. **Rebound damping** is adjusted by turning the slotted brass adjuster on the top cap of the right leg. The adjuster has 8 turns of adjustment. Turn the adjuster clockwise for slower rebound. To speed up rebound, turn the adjuster counter-clockwise. Start with a middle setting and fine tune the rebound from there. Proper rebound will allow the tire to track the ground over consecutive bumps. Rebound that is set too slow will pack-up (feel harsh over consecutive bumps) while rebound set too fast will cause the fork to top out harshly. If the fork is topping out and you have the correct spring for your weight, turn the adjuster one turn at a time until the top-out stops.
2. **Compression damping** can be adjusted by adding or removing air pressure (or nitrogen) from the damper leg. The schrader valve for adjusting the air pressure is located on the right fork leg drop-out. Remove the valve cover and adjust between 50 psi min. and 150 psi. max. Adding air will increase the compression damping (slow it down) and removing air will decrease compression damping (faster compression). Less compression damping will increase the fork dive but will feel smoother over small bumps. More compression damping will feel stiff over small bumps but will be more resistant to bottoming.

MAINTENANCE

Your White Brothers fork requires periodic maintenance to ensure peak performance and long life. Neglecting proper maintenance will reduce the fork's life. Internal build up of water and dirt or a lack of lubrication will cause excessive wear and void the warranty.

BEFORE EVERY RIDE: Visually inspect your fork for bent or broken parts, loss of oil, abnormal sounds or other indications of possible fork failure. Compress you fork to verify proper function. Check all other bicycle components to ensure proper working order.

AFTER EVERY RIDE: Clean and dry the exterior of your fork. When cleaning the fork, do not direct the water spray at the seals. Visually inspect your fork for damage.

***EVERY 30 HOURS OF RIDING:** Your fork should be disassembled, inspect, cleaned and re-grease. If the fork appears to be relatively clean, you can go 40 hours between servicing. If the fork appears excessively dirty you should service it every 20 hours. The three things that will effect the service interval and performance of your fork are water, mud and dust. How much you use your fork in those conditions will determine how much service it requires.

***EVERY 100 HOURS OF RIDING:** Complete service should include removing the upper fork legs cleaning and re-greasing all shafts, bushings and seals. Check damper leg for proper function(see Disassembly of the Damper Leg). NOTE: Disassembly of the hydraulic damper should be left for the White Brothers factory. At this time, the fork should be carefully inspected for wear and damage before reassembly. Contact White Brothers for replacement parts and service. We recommend that this service be performed by a qualified dealer or the White Brothers factory.

***White Brothers recommends that you consult with a qualified technician before performing the following:**

BASIC FORK DISASSEMBLY

Removal of the Leg Assemblies

1. Disconnect the front brake and loosen the pinch clamp bolts at the bottom of each leg. Un-thread the axle with a 17mm wrench and remove the wheel.
2. Loosen the four M6 upper clamp bolts. Before loosening the lower clamp bolts, start to loosen the top caps using a 25mm or 1" socket. Then loosen the lower clamp bolts and slide the legs out of the clamps.

Disassembly of the Spring Leg Assembly (Left Hand)

1. Unscrew the top cap from the outer leg. Check for noticeable play between the stanchion tube and the outer fork tube. If there is play, contact White Brothers or a qualified dealer for service.
2. Place the axle clamp into a vise with soft jaws or some type of protection that will not harm the finish. Lower the outer leg until the seal touches the axle clamp.
3. Slide a 9/16" or 15mm wrench in between the coils of the small spring and loosen the jam nut. Hold the nut and unscrew the top cap counterclockwise from the shaft.
4. Remove the jam nut, single sided spacer and main spring from the shaft.
5. Remove the leg from the vise and remove the inner leg from the outer leg. Return the leg to the vise and remove the spring guide from the inner leg using a 19mm or 3/4" wrench.
6. Normally, it's unnecessary to remove the anti bottoming system from the inner leg, but it is a good idea to shine a flashlight down inside to visually inspect the compression bumper. If it looks damaged, use a spoke or a coat hanger to hook the bumper and pull it out. Replace with a new bumper.
7. Clean and inspect all the parts. Check the DU bushings inside the outer leg carefully for wear. This is done by looking at the color of the clean bushings. If the bushings are dark gray, they are in good condition. If they are bronze/gold in areas, they are worn and can cause fork stanchion damage. Please note that special tools are required to remove and replace these bushings. This service can be performed directly through White Brothers or a qualified dealer.
8. Next, inspect the fork stanchion tubes for wear, nicks or scrapes. These will cause premature wear on the seals and DU bushings. If there is any damage to the stanchion tubes, have them replaced.

Disassembly of the Damper Leg Assembly (Right Hand)

NOTE: 10mm Clamp Blocks are required to work on the damper side leg. Contact White Brothers for the proper tools.

1. Unscrew the top cap from the outer leg. Check for noticeable play between the stanchion tube and the outer fork tube. If there is play, contact White Brothers or a qualified dealer for service. Slide the outer leg down to the axle clamp.
2. Carefully clamp the shaft in the vise using 10mm clamp blocks. *Note: You can easily damage the shaft by scratching or bending it.* When clamping, be sure the fork isn't touching the bench under the vise.
3. Unscrew the top cap counterclockwise from the shaft. *Note there is a small spacer under the cap that can fall out.*
4. Remove from the vise and pull the inner leg out of the outer leg.

BASIC FORK REASSEMBLY

Rebuilding the Outer Legs

1. Thoroughly clean all the parts in a mild solvent.
2. Check the condition of the wiper seals and the inner oil seal for cracks, abrasions or obvious signs of wear. *Note: If the wiper seals are in question, replacement is always recommended.* It helps to keep the dirt out, especially when riding in harsh conditions.
3. The wiper seals can be removed with a spoon style tire iron or something similar and can be re-installed using a large socket as a driver to install squarely in to the leg. *Note: Jamming the seals in at an angle can crush the steel casing and the seal will no longer seal correctly and/or stay in place.*
4. Apply grease to the DU bushings down inside the leg. Verify the bushings are in good working order. Bushings are replaceable but require a number of special tools to remove and install. Return to White Brothers to have the bushings changed if required.

Rebuilding the Spring Leg Subassembly

1. Thoroughly clean all the parts in a mild solvent.
2. Check the condition of the rebound and compression bumpers and replace if necessary.
3. Rebuild the dummy shaft starting from the bottom. First the rebound bumper, the delrin washer, rebound spring, rebound bumper spacer that goes inside the rebound spring and finally the spring guide attached to the rebound spring. Thread the assembly into the inner leg.

Rebuilding the Damper Leg Assembly

1. Thoroughly clean all the parts in a mild solvent.
2. Inspect for obvious signs of damage. Check the air pressure. Test the damper by pushing the shaft down. It should compress and return in a controlled manner. At the top of the stroke, check for dead spots in the damping and if the damper shaft does not return to full extension or you see oil, this indicates the need for damper service. Contact White Brothers for service.

Reinstalling the Outer Legs

1. Apply Slick Honey or other non-lithium based suspension lube to the DU bushings inside the outer leg. Make sure to lube the lower DU bushing which is deep in the outer leg.
2. With all parts cleaned and reinstalled with new grease, fit the outer leg over the stanchion and gently rock and slide the legs until the inner leg slides into the bushings. **Note: Do not tap the outer leg onto the stanchion tubes. The DU bushings can be dislodged.** Slide the outer leg all the way down to the axle clamp. Check for noticeable play between the stanchion tubes and the fork lower. If there is play, contact White Brothers for service.

Reinstalling the Springs and LH Top Cap

1. Pull the dummy shaft out to full extension. If additional pre-load is needed, drop the pre-load shims over the control rod and down onto the spring guide.
2. Carefully slide the main spring, covered in grease, over the shaft and down onto the spring guide. Install the single sided spring guide on top of the main spring and then thread the jam nut onto the shaft until it stops.
3. Hold the top cap with a 15/16" socket and tighten the jam nut with a 9/16" wrench up against the top cap to lock them in place. Apply grease to the auxiliary spring.
4. Thread the top cap into the outer leg and tighten. *Note: A little more than hand tight is all that is necessary, as the upper clamp will hold the top caps tight.*

Reinstalling the RH Top Cap

1. Screw the rebound needle in clockwise until it stops then back it out 3 to 4 turns.
2. Install the small spacer under the top cap if you removed it earlier.
3. Carefully clamp the shaft in the 10mm clamp blocks. *Note: You can easily damage the shaft by scratching or bending it.* When clamping, be sure the fork isn't touching the bench under the vise.
4. Install the top cap onto the damper shaft and tighten. Remove the assembly from the vise and thread the top cap into the outer leg and tighten. *Note: A little more than hand tight is all that is necessary, as the upper clamp will hold the top caps tight.*
5. Readjust the rebound needle to your preferred position.

Exploded Views

The following is an illustration and parts table which gives you the exploded view of your White Brothers fork. The parts table indicates the part numbers for each individual part in the fork.

Reference these numbers when ordering replacement parts. See your local dealer or contact White Brothers to order the parts you require.



DH 1.8
Coil Fork

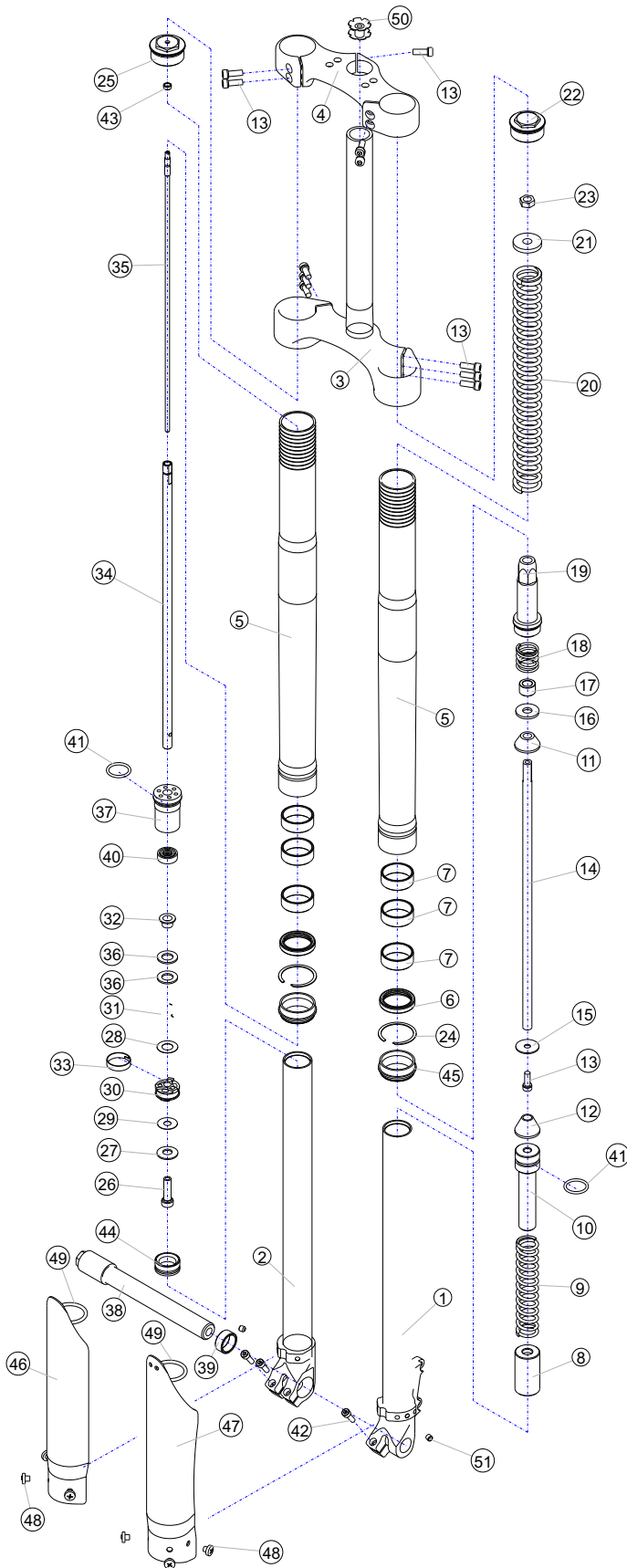

ITEM NO	QTY	PART NO.	DESCRIPTION
1	1	P1541	Leg Assembly LH DH
2	1	P1540	Leg Assembly RH DH
3	1	P1159-1	Crown Assembly DH 2.0
4	1	P1157-1	Upper Crown DH-3
5	2	100021-100022	Outer Leg DH 2.0
6	2	P3060	Oil Seal
7	6	97-986	DU Bushing
8	1	P3307	Bottomer Seat
9	1	97-3500	Bottom Out Spring
10	1	P3309	Bottomer Stop
11	1	97-3342	Bumper Soft
12	1	97-3341	Bumper Hard
13	12	97-852	Bolt M6
14	1	P2026	UD 180 Dummy Rod
15	1	97-4110	Washer
16	1	P3321	0.1" Delrin Washer
17	1	P3322	Shaft Top
18	1	P3208	Negative Spring
19	1	P3304-2	Spring Guide Lower
20	1	100040	Main Spring
21	1	P2503	Single Sided Washer
22	1	P2349	Fork Cap UD 180
23	1	97-4100	Jam Nut
24	2	P4301	C Clip
25	1	P2348	Damping Cap UD DH-2
26	1	P4010	Shim Stack Bolt
27	1	P2005	Belvil Washer
28	1	P2004	Check Valve 22x12x0.02
29	1	P2006	Low Spd Shim 22x8x0.02
30	1	P2012	Piston
31	1	P2015	Check Valve Spring
32	1	P2014	Check Valve Guide
33	1	P3000	Piston Band
34	1	P2028	DH-3 Damper Shaft
35	1	P2035	Needle Assembly
36	2	P3315-1	Pre-load Washer
37	1	P2201-1	Seal Head
38	1	97-3677	Axle
39	1	97-3677-1	Axle Spacer
40	1	97-1409	Shaft Seal
41	2	P3021	O-Ring -118
42	3	97-9200	M5x16mm Screw
43	1	P2025-1	Shaft Stop
44	1	P2010	Floating Piston Assembly
45	2	97-1351	Wiper Seal
46	1	98-406-1	LH Stone Guard
47	1	98-406-2	RH Stone Guard
48	6	P4005	Screw Nylon Guard Guide
49	2	P3027	O-Ring -218
50	1	97-9300	Star Nut
51	2	P4051	M6 Set Screw

Owners Name: _____
 Address: _____

 Phone: _____
 Purchase Date: _____
 Purchase Location: _____
 Serial #: Located on lower back side of right axle clamp. _____

MAINTENANCE LOG

Date	Service Performed

Date	Service Performed

WARRANTY CLAIMS

White Brothers forks are designed to enhance riding pleasure and as such are warranted to be free from defects in materials and workmanship for a period of one year from the date of purchase. On receipt of the fork, if it is found to be defective, White Brothers will determine replacement or repair of the fork. This warranty is the sole and exclusive remedy. White Brothers shall not be liable for any indirect, special or consequential damages. Warranty does not apply to any product that has been installed improperly or adjusted using methods not outlined in this manual. Warranty also does not cover forks that have been misused, or forks that have missing/altered serial numbers (located on the back of the right fork stanchion). The fork is not warranted against damage in the appearance of the fork or for modifications not outlined in this manual. This warranty does not cover breakage, bending, or damage that may result from crashes, falls or abuse. Normal wear (i.e. seals, bushings, sliders finish, etc) and wear and damage caused by lack of proper maintenance is not included. ***The warranty registration card must be filled out and returned within 30 days of purchase to activate and validate this warranty.** A copy of the proof of purchase must be included with all warranties. Customers in the US please contact White Brothers or your dealer for a Return Authorization Number (RA#) before returning the forks. All forks returned for inspection must be sent freight paid to:



580 N. Westgate Dr.
 Grand Junction, CO 81505 USA
 1.800.999.8277
 Www.whitebrotherscycling.com

