

OWNERS MANUAL FOR

DT 1.2



580 N. Westgate Dr.
Grand Junction, CO 81505 USA
1.800.999.8277
www.whitebrotherscycling.com



A division of
Eko SPORT, INC.

TABLE OF CONTENTS

SAFETY.....	PAGE 2
INTRODUCTION.....	PAGE 2
FORK INSTALLATION.....	PAGE 3
TUNING.....	PAGE 4
MAINTENANCE.....	PAGE 5
TROUBLE SHOOTING.....	PAGE 6
EXPLODED VIEWS.....	PAGE 7
WARRANTY.....	PAGE 8

IMPORTANT **CONSUMER SAFETY INFORMATION**

WARNING: RIDING A BIKE IS DANGEROUS. NOT PROPERLY MAINTAINING OR INSPECTING YOUR BIKE AND IT'S COMPONENTS IS EVEN MORE DANGEROUS. IT IS ALSO DANGEROUS TO NOT READ AND FOLLOW THESE INSTRUCTIONS.

1. NEVER REMOVE STEERER TUBE FROM CROWN. THIS IS APRESSED IN PART. REMOVING IT WILL RENDER BOTH THE CROWN AND STEERER TUBE INOPERABLE.* MAKE SURE THE FORK CAPS AND ALL FORK HARDWARE (brake studs, pinch bolts, etc.) ARE TIGHT BEFORE EACH RIDE.
2. DO NOT PERFORM ANY MODIFICATIONS OR ADJUSTMENTS THAT ARE NOT OUTLINED IN THIS MANUAL. SEE THE TUNING SECTION FOR MORE DETAILS.
3. INSPECT YOUR FORK BEFORE EVERY RIDE. INSPECT THE CROWN, TUBES, AND AXLE SEAT AREAS FOR ANY SIGNS OF FATIGUE, BENDING, CRACKING OR OTHER DAMAGE. IF YOU NOTICE ANY TYPE OF DAMAGE, DO NOT RIDE IT. RETURN IT TO YOUR DEALER OR TO WHITE BROTHERS FOR A COMPLETE INSPECTION AND NECESSARY REPAIR.
4. THIS WHITE BROTHERS FORK IS DESIGNED WITH A LOCKOUT THAT TURNS OFF THE FORK'S SUSPENSION. THE LOCKOUT IS ONLY DESIGNED TO BE USED ON SMOOTH TERRAIN. USING THE LOCKOUT ON ROUGH TERRAIN, BUMPS OR DROP-OFFS CAN CAUSE SERIOUS DAMAGE TO THE FORK AND COULD CAUSE SERIOUS PERSONAL INJURY OR DEATH.
5. PERFORM ALL RECOMMENDED MAINTENANCE ACCORDING TO THE MAINTENANCE SECTION OF THIS MANUAL. FAILURE TO PERFORM MAINTENANCE COULD DRASTICALLY REDUCE THE FORK'S LIFE, PERFORMANCE AND CAUSE YOUR FORK TO BE A SAFETY HAZARD.
6. WHITE BROTHERS RECOMMENDS THAT YOU WEAR PROPER SAFETY EQUIPMENT EVERY TIME YOU RIDE, INCLUDING APPROVED BICYCLE HELMET. NEVER RIDE AT NIGHT WITHOUT LIGHTS.
7. ALWAYS USE GENUINE WHITE BROTHERS PARTS. USE OF AFTERMARKET REPLACEMENT PARTS AND UPGRADES VOIDS THE WARRANTY AND COULD CAUSE STRUCTURAL FAILURE.
8. WHITE BROTHERS FORKS ARE DESIGNED FOR OFF ROAD USE ONLY. THEY ARE NOT EQUIPPED WITH REFLECTORS FOR ROAD USE. IF YOU ARE GOING TO USE YOUR FORK ON THE ROAD, HAVE A DEALER OR MECHANIC INSTALL REFLECTORS THAT MEET THE CONSUMER PRODUCT SAFETY COMMISSION'S REQUIREMENTS.

**IF SERVICE BECOMES NECESSARY OR REMOVAL OCCURS, PLEASE CALL WHITE BROTHERS CUSTOMER SERVICE FOR PRODUCT EVALUATION AND DIAGNOSIS.*

INTRODUCTION

Thank you for purchasing your new White Brothers fork. Our forks are designed to help you perform at your absolute peak. Your new White Brothers fork has oil damping and is coil sprung for light weight performance. The coil spring and damper is set stock to satisfy a wide range of rider weights and riding styles. Fine tuning can be easily accomplished by changing pre-load and external damper settings. See the tuning section for details. For very heavy or very light riders, replacement springs are available. Steering accuracy is improved over conventional MTB forks by utilizing superior materials and design. These include oversized 32mm fork tubes, a torsion box design steering crown with pressed in tubes, a one piece billet brake arch and extra thick drop-outs. The WB bootless design allows a considerable amount more slider/stanchion overlap than competitor forks which increases fork steering accuracy. The travel on your fork is externally adjustable, allowing you to adjust the travel to your bikes geometry and the terrain that you are riding. Every effort has been made to make White Brothers forks very light and perform at a level superior to other forks on the market. To ensure peak performance, proper installation and periodic maintenance is required. When riding on public land, please respect the rights of others and stay on established paths and trails. By riding responsibly, you are helping ensure the future of our sport.

FORK INSTALLATION

White Brothers forks feature a 1-1/8" threadless steer tube. If you have a threaded type fork on your bicycle, consult your dealer for the appropriate upgrade parts necessary to convert to a 1-1/8" threadless steerer tube.

1. Remove your old fork from the bicycle. Measure the diameter and length of your old forks steerer tube to ensure that the White Brothers steerer tube is the correct diameter and sufficient length for the installation.
2. Remove the crown race from your old fork.
3. Press the crown race onto your new White Brothers fork. **(see Figure #1)**
4. Preassemble the headset by sliding the fork steerer tube through the bearings. Then install the headset upper race, headset spacer (optional), and stem onto the fork steerer tube. Adjust with optional spacers to your preferred height. **(See Figure #2)** Refer to the headset owners manual if there is any questions about the pre-assembly.
5. Mark the steerer tube at the top of the stem. The steerer tube will now need to be cut to the correct length. Disassemble and cut 3mm (1/8") below the mark. Consult your dealer or mechanic if you don't have the proper tools to cut the steerer tube.
6. The star fangled nut must now be installed into the steerer tube. If you don't have the set tool, we recommend dealer installation of this part. **(See Figure #3)**
7. Clean and grease all headset bearings and races to prepare them for assembly. *Note: Replace the bearings if there is any sign of wear or corrosion.*
8. Now loosely assemble the headset, stem and handle bars as done in step four.
9. Install the headset top cap into the star fangled nut. Tighten until there is no play in the steering. The fork should rotate freely in the head tube. Straighten the stem in relation to the front tire and tighten the pinch bolts on the stem. If there are any questions consult your dealer or mechanic.
10. Install your front brake and adjust according to the manufacture instructions.
11. Install and tighten the wheel in the front fork. Tighten the 20 mm thru axle nut and the pinch bolts.
12. Check to see that the brakes are adjusted and properly working. Make sure that the brake cable does not interfere with any part of the bike when the fork is compressed and released.

Warning: When installing the wheel or a new tire, check for minimum clearance. Measure from the highest point on the tire to the under side of the crown. There must be 1/8" or 3mm more clearance than the fork travel to ensure adequate clearance in all riding conditions. Any less clearance can result in the tire hitting the crown resulting in serious injury or death.

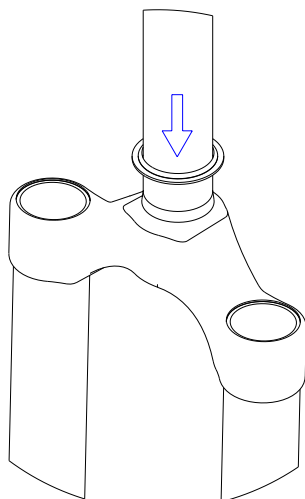

Figure #1

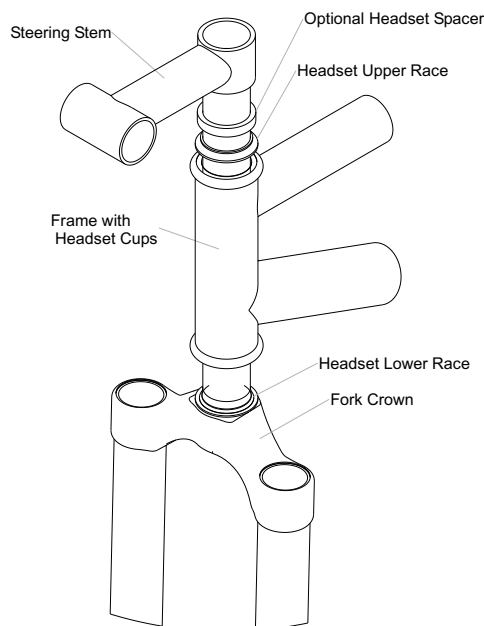

Figure #2

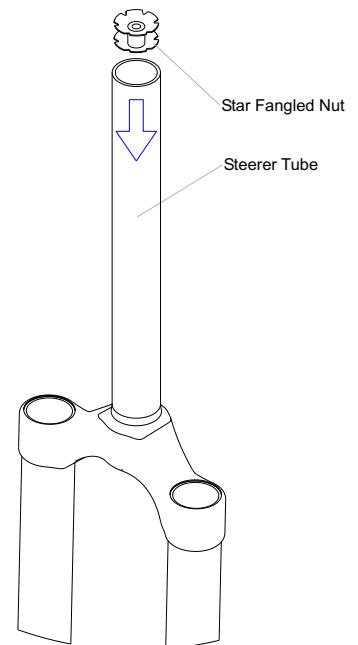

Figure #3

TUNING

To get the most out of your White Brothers fork, it is important that you tune the fork to fit your weight, riding style and the terrain you ride.

INITIAL BREAK-IN PERIOD:

Your new fork is designed to break-in over a period of 10 hours or more of riding. As all the parts bed into each other, the stiction (friction) of the fork decreases and the sensitivity increases. After the initial break-in period, fine tuning the spring pre-load or rate and damping adjustments may be beneficial to achieve the best possible performance.

TOOLS NEEDED:

15/16" socket with ratchet.
4mm Allen wrench
6mm Allen wrench

COIL SPRING / OIL DAMPER

Your new White Brothers fork is designed with a coil spring and oil damping. The following guidelines for adjusting and maintaining your fork will enable you to enjoy maximum performance and longevity from your fork.

1. First, test ride the fork over easy terrain. If after riding the fork over varied terrain you decide that more tuning is necessary, continue to the next step.
2. The compression or spring of the fork can be changed four ways: 1) by adjusting the travel 2) by adjusting the pre-load 3) by adjusting the settings of the damper and 4) by changing the spring for a spring with a different rate.
3. To adjust the travel remove the lower assembly from the stanchions. Remove the spring side stanchion plug (left leg) and remove the control rod. Remove the control rod top using a 15mm wrench and a 3mm allen or tiny screw driver slipped through the hole in the control rod. Travel changes by flipping the control rod top upside down and re-installing. With the adjustable top covering part of the rod (shorter assembly), you get 100mm of travel and with the adjustable top not covering part of the rod (longer assembly), you get 120mm travel.
4. To change the pre-load, remove the dust cap and turn the allen fitting on the top of the left fork leg. Turn to the right to add pre-load to the spring. Turn to the left to reduce spring pre-load. You should always have some pre-load on the spring to keep it from rattling inside the fork leg.
5. **Compression adjustment** is done by adding or removing air at the top of the right leg. Pressures can range from 50 to 150 lbs. Higher air pressure will provide more compression damping while lower air pressure will provide less compression damping. Less compression damping will increase the fork dive but will feel smoother over small bumps. More compression damping will feel stiffer over small bumps but will be more resistant to bottoming. **DO NOT COMPRESS FORK WITHOUT AIR IN DAMPER!**
6. **Rebound adjustment** is done by turning the knob on the bottom of the right leg. Turn the knob clockwise for slower rebound. To speed up rebound, turn the knob counter-clockwise. Start with a middle setting and fine tune the rebound from there. Proper rebound will allow the tire to track the ground over consecutive bumps. Too slow of rebound will pack-up (feel stiff over consecutive bumps) while rebound set too fast will cause the fork to top out harshly. Adjustment range is 6 turns.
7. If after adjusting as outlined in steps 3-5 you feel the fork is too soft or too firm, you may need to replace the spring with a spring with a lighter or stiffer spring rate. **(See Figure #4)** Contact White Brothers to replace the spring. To replace the spring, remove all pre-load by backing the pre-load adjuster out then remove the top cap using a 15/16" socket to expose the spring. Pull the spring out and replace with the new spring. (Reference exploded view for part #) Reinstall the pre-load adjuster and top cap, threaded tightly into the crown.

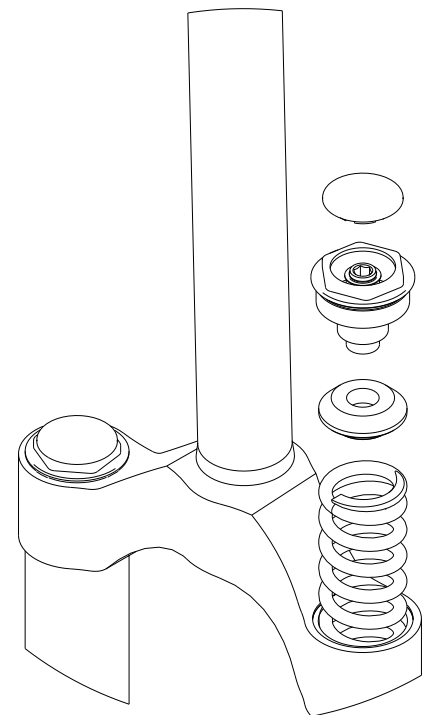
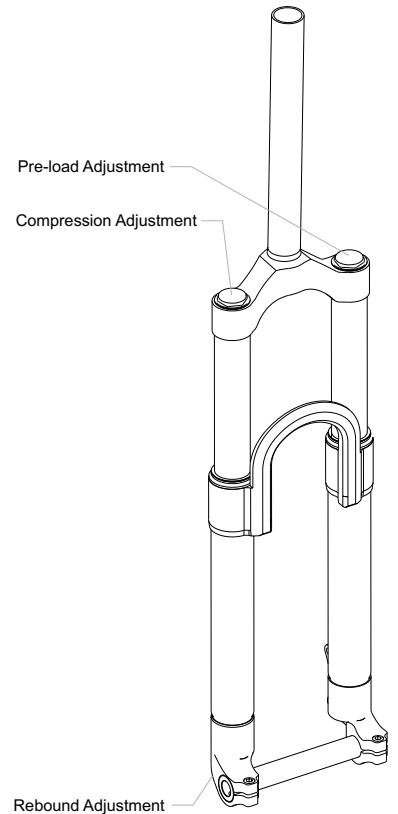

Figure #4

MAINTENANCE

Your White Brothers fork requires periodic maintenance to ensure peak performance and long life. Neglecting proper maintenance will reduce the fork's life. Internal build up of water and dirt or a lack of lubrication will cause excessive wear and void the warranty.

BEFORE EVERY RIDE: Visually inspect your fork for bent or broken parts, loss of oil, abnormal sounds or other indications of possible fork failure. Compress your fork to verify proper function. Check all other bicycle components to ensure proper working order.

AFTER EVERY RIDE: Clean and dry the exterior of your fork. When cleaning the fork, do not direct the water spray at the seals. Visually inspect your fork for damage.

***EVERY 30 HOURS OF RIDING:** Your fork should be disassembled, inspect, cleaned and re-grease. If the fork appears to be relatively clean, you can go 40 hours between servicing. If the fork appears excessively dirty you should service it every 20 hours. The three things that will effect the service interval and performance of your fork are water, mud and dust. How much you use your fork in those conditions will determine how much service it requires.

***EVERY 100 HOURS OF RIDING:** Complete service should include removing the lower fork legs cleaning and re-greasing all shafts, bushings and seals. Check top cap assembly's, damper cartridge, stanchion plug, brake post bolts and shaft bolts for proper torque. At this time, the fork should be carefully inspected for wear and damage before reassembly. Contact White Brothers for replacement parts and service. We recommend that this service be performed by a certified White Brothers service center or by the factory.

*White Brothers recommends that you consult with a qualified technician before performing:

Basic Fork Disassembly and Inspection

1. Disconnect the front brake and remove the wheel as outlined in you bicycle owners manual.
2. Pop out the damping adjuster knob from the bottom of the right dropout. Loosen the allen bolts at the bottom of the fork legs(See figure #5) on either QR and 20mm dropouts. A light tap may be needed to free the control rod from the lower assembly. Finish removing the compression screws.
3. Simply slide the fork legs off the end of the inner stanchion tubes. Be careful not to damage the seals as they come off the inner legs.
4. Check the air pressure in the damper. It should be between 50 and 150 psi. Inspect the damper leg for visible leakage. If none, grasp the shaft while in the stanchion tube and operate back and forth to insure smooth action. If the damper has visible leakage and/or the damping feels inconsistent as it is stroked, return the fork to White Brothers or a dealer familiar with rebuilding the damper for service. The damper is a sealed unit and should not be opened unless service is required. Damper service should be performed by White Brothers.
5. Clean all parts with a clean, non-abrasive rag. A mild grease cutting cleaner or solvent might make this an easier task. Once clean, inspect the seals for tears or cracks. If in good condition, re-grease them with Slick Honey or other suitable non-lithium grease. If your seals show signs of wear have them replaced.
6. Check the DU bushings carefully for wear. This is done by looking at the color of the bushings. If the bushings are dark gray, they are in good condition. If they are bronze/gold in areas, they are worn and can cause fork stanchion damage. If there is noticeable movement back and forth when the legs are fully engaged on the fork stanchions, the DU bushings may need to be replaced. Please note that special tools are required to remove and replace these bushings. This service can be performed by certified White Brothers MTB service centers or directly through White Brothers.
7. Next, inspect the fork stanchion tubes for wear, nicks or scrapes. These will cause premature wear on the seals and DU bushings. Check again for noticeable play between the stanchion tubes and the fork lower.
8. If everything is free of problems, coat all parts with a liberal coat of Slick Honey or other non-lithium grease. Be sure to lube the DU bushings located inside the lower leg.

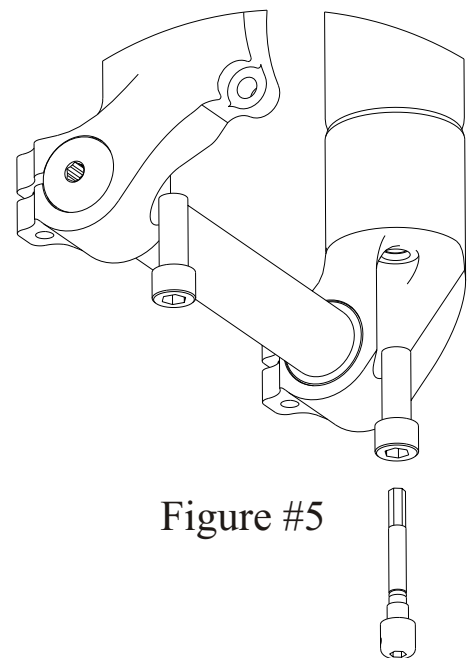

Figure #5

Basic Fork Reassembly

1. Make sure all the spacers and bottoming bumpers are installed on the control rods (see exploded views for proper installation). With all parts cleaned and reinstalled with new grease, fit the lower assembly over the stanchion tubes and gently rock and slide together until the control rods are touching the bottom of the lower assembly. Thread the compression screws into the control rods starting with the damper side and firmly tighten.. Downward pressure on the fork will help hold the control rods from rotating until the compression screws become tight. **Note: Ensure the compression screws are fully tight before riding.**
2. Check the air pressure in the damper leg for proper compression damping. Pressure should be between 50 and 150 psi.
3. Make sure the fork caps are fully tightened into the top of the stanchion tubes. Connect the front brake and wheel as outlined in you bicycle owners manual. Ensure that the QR or 20mm axle nut and pinch clamps are tight before riding.
4. Compress the fork to make sure it works smoothly and the brake cable does not interfere with the operation of the fork.

TROUBLE SHOOTING

Fork Feels Sticky

This is usually caused by:

1. A lack of lubrication. Clean and lubricate the fork as outlined in the maintenance section.
2. Contamination inside the fork. Clean and lubricate the fork as outlined in the maintenance section.
3. Fork is not sufficiently broken in. Contact White Brothers for further technical information.

The Fork Bottoms Too Easily

1. Incorrect spring pre-load. Add spring pre-load as outlined in #3 of the tuning section.
2. Insufficient compression damping. Add compression damping by adding air (50-150 lb range) to the top of the right leg.
3. Too light of spring rate. Change the spring out for a heavier rate as outlined in #6 of the tuning section.

The Fork Doesn't Use Full Travel

1. Incorrect spring pre-load. Remove spring pre-load as outlined in #3 of the tuning section.
2. Excessive compression damping. Reduce the compression damping by removing air (50-150 lb range) from the top of the right leg.
3. Too stiff of spring rate. Change the spring out for a lighter rate as outlined in #6 of the tuning section.

Damping Adjustment is Not Working

1. Damper may need servicing. Contact White Brothers for technical information.

Exploded Views

DT 1.2 80-100mm Coil Fork W/ Oil Damper

The following is an illustration and parts table which gives you the exploded view of your White Brothers fork. The parts table indicates the part numbers for each individual part in the fork.

Reference these numbers when ordering replacement parts. See your local dealer or contact White Brothers to order the parts you require.

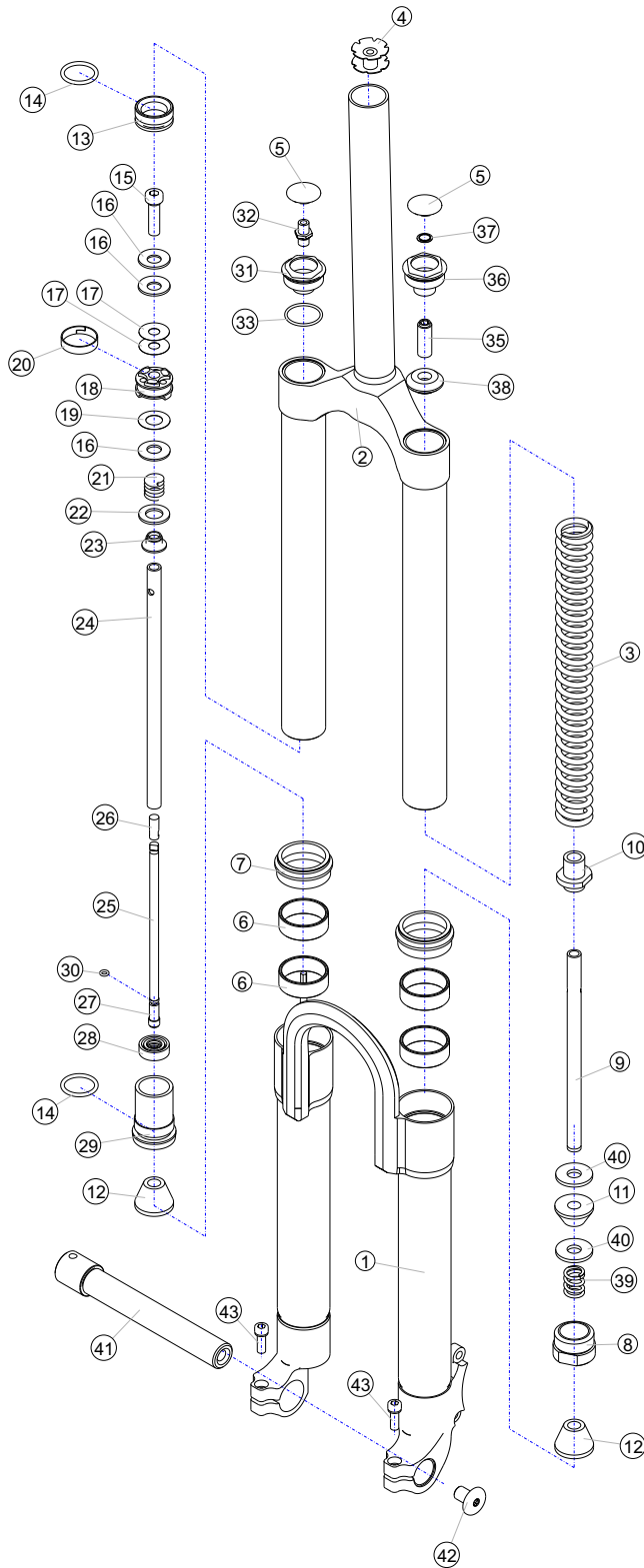

ITEM NO.	QTY.	PART NO.	DESCRIPTION
1	1	100197-20,100199-20	20mm Lower Assembly
2	1	P1139-2	Upper Assembly
3	1	100188	Main Spring
4	1	97-9301	Star Nut
5	2	P4650	Air Valve Dust Cap
6	4	97-986	DU Bushing
7	2	97-1351	Wiper Seal
8	1	100235	Stanchion Plug
9	1	100561	Control Rod
10	1	100559	Springs Interface Guide
11	1	97-3342	Bumper
12	2	P3290	Bumper Soft
13	1	P2010	Floating Piston
14	2	P3021	O-Ring 118
15	1	P4010	Shim Stack Bolt
16	3	P2005	Belleville Washer
17	2	P2006	Rebound Shim
18	1	P2012	DH Piston
19	1	P2004	Compression Shim
20	1	P3000	Piston Ring
21	1	P2015	Check Valve Spring
22	1	P3315-1	Preload Washer
23	1	100602	Check Valve Guide
24	1	100049	Damper Shaft
25	1	100065	Damper Adjuster Extension
26	1	100050	Damper Adjuster Part
27	1	100064	Adjustment Needle for FR1.5
28	1	97-1409	Damper Shaft Seal
29	1	P2201-1	2003 DH Seal Head
30	1	ZTA-ORING-006	O-Ring 006
31	1	100060	Air Cap Triple Clamp Series
32	1	100054	Schrader Valve Assembly
33	1	P3028	O-Ring 021
34	2	100063	Compression Screw
35	1	100560	Preload Cap Core
36	1	100067	Preload Cap FR 1.5
37	1	100068	E-Clip 38
38	1	97-3555	Negative Spring Spacer
39	1	100016	Negative Spring
40	2	P3321	0.1" Delrin Washer
41	1	100285	20mm Axle
42	1	100531	20mm Axle Nut
43	2	97-852	M6 Allen Cap Screw
44	1	100200	Rebound Adjuster

Owners Name: _____
 Address: _____

 Phone: _____
 Purchase Date: _____
 Purchase Location: _____
 Serial #: Located on lower back side of right axle clamp. _____

MAINTENANCE LOG

Date	Service Performed	Date	Service Performed

WARRANTY CLAIMS

White Brothers forks are designed to enhance riding pleasure and as such are warranted to be free from defects in materials and workmanship for a period of one year from the date of purchase. On receipt if it is found to be defective, White Brothers will determine replacement or repair of the fork. This warranty is the sole and exclusive remedy. White Brothers shall not be liable for any indirect, special or consequential damages. Warranty does not apply to any product that has been installed improperly or adjusted using methods not outlined in this manual. Warranty also does not cover forks that have been misused, or forks that have altered/missing serial numbers (located on the back of the right fork stanchion). The fork is not warranted against damage in the appearance of the fork or for modifications not outlined in this manual. This warranty does not cover breakage, bending, or damage that may result from crashes, falls or abuse. Normal wear (i.e. seals, bushings, sliders finish, etc) and wear and damage caused by lack of proper maintenance is not included. ***The warranty registration card must be filled out and returned within 30 days of purchase to activate and validate this warranty.** A copy of the proof of purchase must be included with all warranties. Customers in the US please contact White Brothers or your dealer for a Return Authorization Number (RA#) before returning the forks. All forks returned for inspection must be sent freight paid to:



580 N. Westgate Dr.
 Grand Junction, CO 81505 USA
 1.800.999.8277
 www.whitebrotherscycling.com

